

Generation of Coherent Multi-Carrier Signals by Gain Switching of Discrete Mode Lasers

P. M. Anandarajah¹, *Member, IEEE*, R. Maher¹, *Member, IEEE*, Y. Q. Xu³,
S. Latkowski¹, *Member, IEEE*, J. O'Carroll², S. G. Murdoch³, R. Phelan², *Member, IEEE*,
J. O'Gorman², L. P. Barry¹, *Member, IEEE*

¹*Research Institute for Networks and Communications Engineering, School of Electronic Engineering, Dublin City University (DCU), Dublin 9, Ireland*

²*Eblana Photonics, Trinity College Enterprise Centre, Pearse Street, Dublin 2, Ireland*

³*Physics Department, University of Auckland, Private Bag 92019, Auckland, New Zealand*

DOI: 10.1109/JPHOT.2010.XXXXXXX
1943-0655/\$25.00 ©2010 IEEE

Manuscript received 2010.

Abstract: The authors demonstrate the generation of a highly coherent multi-carrier signal consisting of eight clearly resolved 10.7GHz coherent sidebands generated within 3dB of the spectral envelope peak and with an extinction ratio in excess of 45dB, by gain switching a discrete mode (DM) laser. The generated spectral comb displays a corresponding picosecond pulse train at a repetition rate of 10.7GHz with a pulse duration of 24ps and a temporal jitter of ~450fs. The optical spectra and associated pulses of the gain switched DM laser are subsequently compared to a gain switched DFB laser that generates a spectrum with no discernible sidebands and corresponding pulses with ~3ps of temporal jitter. The temporal jitter of the gain switched DFB laser is then reduced to <1ps, resulting in visible tones on the output spectrum, via external injection. Finally, a nonlinear scheme is employed and initially tailored to compress the optical pulses and later to expand the original frequency comb from the gain switched DM laser.

Index Terms: Frequency combs, injection locked lasers, pulse compression, optical communications.

1. Introduction

The extensive increase in bandwidth usage shows no sign of abating and is pushing service providers to deploy long haul, metro and access networks with increased capacity. With this continued push for higher capacities, carriers are resorting to upgrade the WDM systems by deploying higher wave counts or higher capacities per wavelength. One of the factors that has been attracting a lot of attention, with the move to higher line rates, is the information spectral density achieved at the transmitter. A promising approach entails the use of multi-carrier spectrally efficient transmission techniques with the sub-channel spacing equal to the symbol rate of each sub-channel [1]–[4]. This can be achieved by electrically generated orthogonal frequency division multiplexing (OFDM) [1], all optically generated OFDM [2], the combination of both electrical and optical OFDM [3] or coherent wavelength division multiplexing (CoWDM) [4]. A vital component that enables CoWDM is the optical frequency comb source (OFCS), which generates the coherent optical multi-carrier signal. The cost and simplicity of these sources are vital factors that will determine the applicability of this technology especially in the price sensitive metro and access

networks.

Most of the earlier reports on all optical implemented OFDM/CoWDM have used single or cascaded Mach Zehnder modulators (MZM) to generate the phase correlated optical comb [5], [6]. Although this technique provides a relatively flat optical comb, the large insertion loss of the modulator coupled with the modulation efficiency can prove prohibitive. The extra optical component also adds to the cost and complexity of the transmitter, rendering this technique unsuitable for short reach applications. Another conventional technique entails the use of harmonic mode locking of a semiconductor laser, which subsequently generates an optical frequency comb with a comb spacing equal to the repetition rate of the pulse train [7], [8]. Although this technique can generate multi-carrier signals spanning over a wide bandwidth, it inherently suffers from cavity complexity and fixed frequency spacing.

In this paper, we extend and improve previous work on gain switching of a discrete mode (DM) laser diode [9] to generate a highly coherent eight-carrier signal spaced by 10.7GHz, and also compare the gain switching performance of DM lasers with that of conventional distributed feedback (DFB) laser diodes for the generation of an optical comb. The results show that the high SMSR and low jitter pulses, which exhibit a corresponding multi-tone spectrum, has potential to be employed as a frequency comb generator. Such a comb generator enables simple and cost efficient generation of lightwaves with the precisely controlled channel spacing required for high information spectral density communication systems. Conversely, the results clearly show that the commonly used DFB laser cannot be used for efficient comb generation (coherent pulse generation) thereby demonstrating that the DM laser [10], [11] outperforms the standard DFB laser. This variation in performance can mainly be attributed to the superior phase noise characteristics that the DM laser exhibits. This characteristic is further validated, via experimental verification, by the improvement in the performance of the gain switched DFB laser with external injection of light. In order to enhance the commercial applications and viability of the gain switched DM laser as a comb source, we also carry out spectral comb expansion by employing a combination of linear and non-linear pulse compression techniques.

2. Characterization of DM and DFB laser diodes

2.1. DC Characterization

The DM laser used is a commercially available ridge waveguide Fabry-Perot (FP) laser diode constrained to lase in a single mode of the FP cavity. This is achieved by introducing etched features onto the surface of the ridge to create topological refractive index perturbations that select a single mode of the cavity [10]. The device is hermetically sealed in a high-speed package, containing an optical isolator and is temperature controlled. The threshold current is characterized to be 16mA and the device displays a 3dB electrical bandwidth of approximately 11GHz at a bias of 55mA. The emission wavelength when the laser is operated in continuous wave (CW) mode at a bias of 55mA and at room temperature is 1540nm as shown in 1(a).

The measured SMSR, in CW operation, is 48dB as indicated in the Fig.1(a). The suppressed sub-threshold Fabry-Perot modes are visible and the mode spacing corresponds well to the measured chip length of 350 μ m. The modal selectivity due to the etched features can be quantified using the Hakki-Paoli technique [12]. With this approach, the net modal gain (G) is related to the contrast ratio of the cavity resonances ρ in the below-threshold amplified spontaneous emission (ASE) spectrum using:

$$G = \frac{1}{L_c} \ln\left(\frac{1}{r_1 r_2}\right) - \frac{1}{L_c} \ln\left(\frac{\sqrt{\rho} + 1}{\sqrt{\rho} - 1}\right) \quad (1)$$

Fig.1(b) illustrates the amplified spontaneous emission (ASE) spectrum and the overlapped net modal gain (cm^{-1}) for the DM laser. This figure clearly shows the gain difference between the lasing mode and the next competing side mode is $>25\text{cm}^{-1}$, making it harder for competing modes

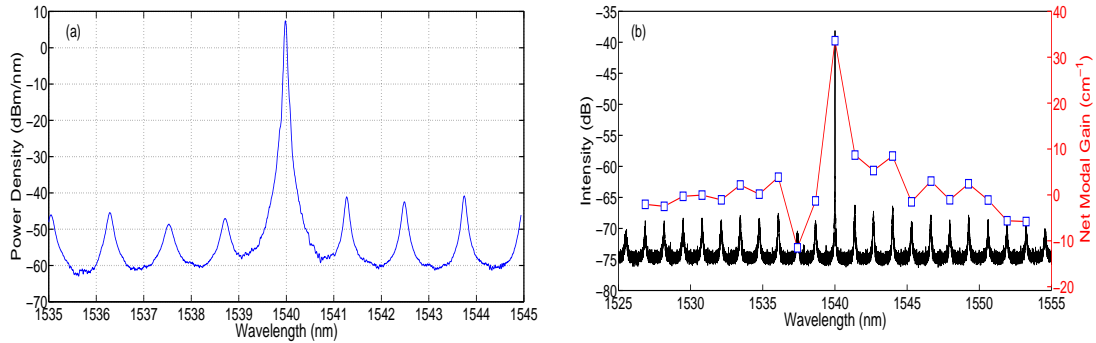

Fig. 1. (a) Optical spectrum of DM laser operating in CW mode. (b) Amplified spontaneous emission (ASE) spectrum with modal gain.

to overcome this gain difference and lase. More importantly, this relatively large gain difference indicates that the coupling of ASE noise into the lasing mode is minimized.

The DFB laser with a cavity length of $\sim 320\mu\text{m}$ is also a commercially available high speed device contained within a temperature controlled hermetically sealed butterfly package. The threshold current was measured to be 15mA and the bandwidth characterized to be 16GHz at a bias current of 55mA. Fig.2(a) shows the CW DFB room temperature emission wavelength of 1545nm at a bias current of 55mA when measured using an optical spectrum analyzer. The measured SMSR is 40dB. Fig.2(b) shows the ASE spectrum and the overlapped net modal gain spectrum (in cm^{-1}) of the DFB laser. The DFB has a quarter wave shifted grating as the Bragg mode is in the centre of the stop band. The gain difference between the Bragg mode and the next competing mode is $\sim 20\text{cm}^{-1}$. This is 20% lower than that exhibited by the DM laser diode, which as opposed to the DM laser, allows more coupling of ASE noise into the lasing mode [13].

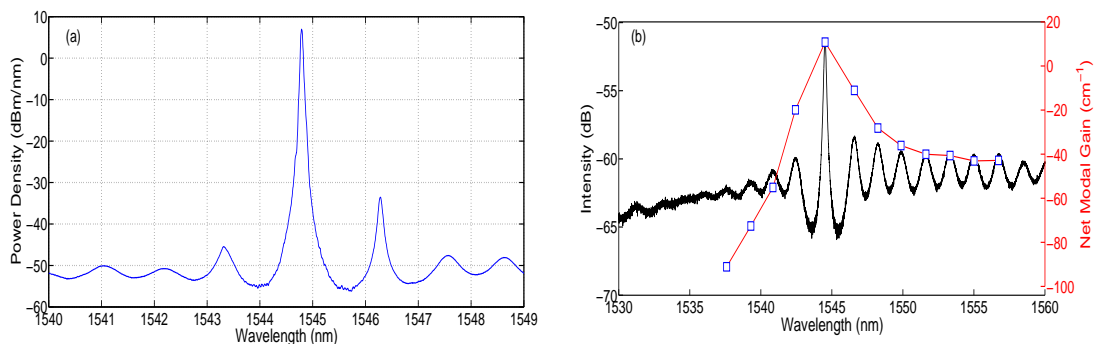

Fig. 2. (a) Optical spectrum of DFB laser operating in CW mode. (b) Amplified spontaneous emission (ASE) spectrum with modal gain.

It has been reported in literature, origin of the linewidth broadening in a semiconductor laser stems from the fact that the phase of the electric field within the laser cavity is perturbed by inherent spontaneous emission noise [13], [14]. In addition, the ASE noise also induces a photon number fluctuation in the cavity that manifests as amplitude noise, which causes a corresponding frequency noise through the change in refractive index with carrier density. Therefore the overall linewidth (phase noise) can be decomposed into the sum of two contributions from the spontaneous emission noise and the frequency noise induced by amplitude variations through refractive index change. Hence, to further outline the differences between the two types of laser transmitters used in this work, in terms of their phase noise properties, we also characterized the linewidth of

each device. It is important to note that both the DM and DFB lasers, used in this experiment, were chosen based on possessing similar high-speed characteristics and closely matched parameters.

2.2. Linewidth Characterization

Fig.3 shows the experimental set-up used to realize the delayed self-heterodyne (DS-H) linewidth characterization [15]. The fiber delay length in one arm of the set-up is 12km (corresponding to a linewidth measurement resolution of ~ 10 kHz). Light propagating in the short arm of the set-up is modulated using a $LiNbO_3$ phase modulator to frequency shift the detected heterodyne beat signal to 2GHz, thereby enhancing the measurement accuracy. The laser linewidth is then deduced from the beat frequency spectrum between the delayed and the non-delayed light, measured using an electrical spectrum analyzer (ESA).

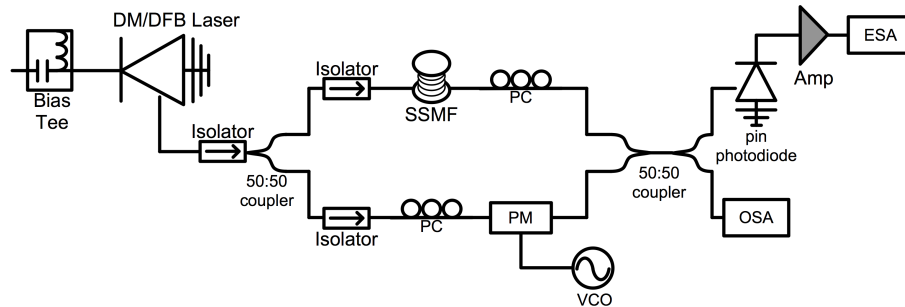

Fig. 3. Experimental set-up for linewidth characterization.

The linewidth of the two lasers (DM and DFB) in CW mode is characterized when they emit fibre coupled output powers of 1 and 2mW and the measured results are shown in Fig.4. The CW linewidth of the DM laser at output powers (bias currents) of 1mW (34mA) and 2mW (55mA) is measured to be 2 and 1.2MHz respectively. The CW linewidth of the DFB laser at output powers (bias current) of 1mW (28mA) and 2mW (48mA) is measured to be 31.8 and 17.8MHz, respectively. This large variation in linewidth between the two types of lasers, when running in CW mode, shows that the DM laser exhibits superior phase noise characteristics.

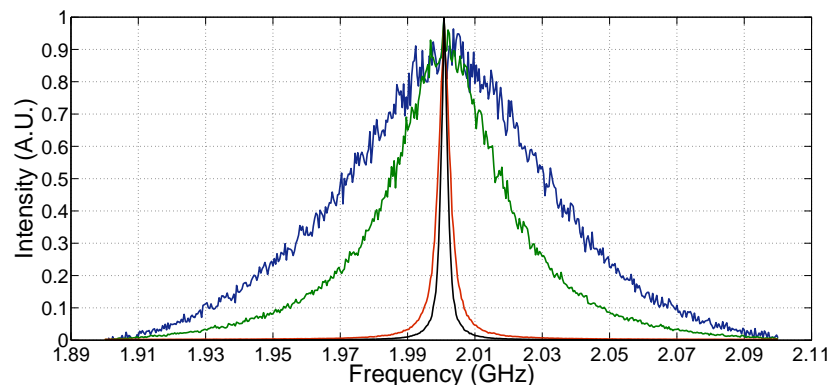

Fig. 4. Linewidths measured using the DS-H method, yellow line: seeded DFB @ 4mW, black line: CW DM @ 1mW, red line: CW DM @ 2mW, green line: CW DFB @ 1mW and blue line: CW DFB @ 2mW.

There are two fundamentally inherent mechanisms that contribute to the narrow linewidth exhibited by the DM laser. Firstly the FP cavity mirror loss strongly enhances one FP mode relative to all other modes that are simultaneously suppressed. This differentially increases the loss for non-lasing cavity modes and reduces the noise amplitude coupled into the lasing mode. Secondly, an

important feature of the DM laser is that the multiple quantum well active region is fabricated in the InGaAlAs material which has a high differential gain. This high differential gain results in a linewidth enhancement factor of approximately 2-3 [16]. As mentioned the laser linewidth induced by the amplitude noise, arises from the spontaneous emission noise through the linewidth enhancement factor [13]. Therefore the linewidth of the DM laser can be maintained at a low value (1-2MHz), relative to that exhibited by the DFB laser (18-32MHz), which typically has an alpha factor of approximately 5.

3. Gain switching of DM and DFB laser diodes

3.1. Experimental Set-up

Fig.5 shows the experimental set-up used to realize the gain switching of the DM and DFB lasers characterised in the previous sections. Gain switching is achieved by applying an amplified 10.7GHz sinusoidal RF signal (24dBm) in combination with a dc bias ($\sim 4I_{th}$) to the laser via a bias tee. The optical output of the laser source is split using a 3dB fiber coupler to enable simultaneous temporal and spectral measurements. The characterization of the multi-carrier signal is carried out by using a high resolution (20MHz) optical spectrum analyzer (OSA) and a high-speed oscilloscope (>65 GHz) in conjunction with a 50GHz pin detector.

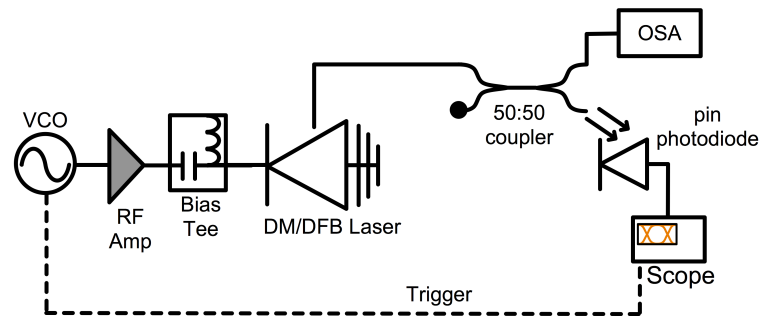

Fig. 5. Experimental set-up for gain switched DM and DFB lasers.

3.2. Results and Discussion

Fig.6(a) shows the spectrum of the gain switched DM laser where the spectral envelope has a full width at half the maximum (FWHM) of approximately 0.5nm. The SMSR is preserved under the high speed modulation and is greater than 45dB, which is highly advantageous in hybrid WDM/OTDM systems [17]. This modulated spectrum also shows efficient sideband generation in the lasing mode (approximately eight, 10.7GHz sidebands are generated within 3dB of the spectral envelope peak) and two small equidistant features on either side of the spectrum corresponding to the sub-threshold FP cavity modes. The high modulation depth of >45 dB indicates the excellent pulse-to-pulse phase stability and also the phase co-relation of the emitted pulses [18]. Fig.6(b) displays the corresponding spectrum of the gain switched DFB laser. In contrast to the gain switched DM laser, modulation of the DFB laser results in a significantly broadened spectrum [8]. In addition, the peak to background spectral contrast reduces to 32dB, which would result in degraded performance if the DFB based transmitter is implemented in a hybrid WDM/OTDM system [17].

Fig.7(a) and (b) show the measured optical pulses from the gain switched DM and DFB lasers, respectively. The pulse width for the gain switched DM laser is 24ps while the pulse width for the gain switched DFB laser is 13ps. We attribute the shorter pulse width of the DFB laser to the relatively higher bandwidth ~ 16 GHz (in comparison to the DM laser which has a bandwidth of 11GHz). More importantly the root mean squared (RMS) jitter of the gain switched DM pulses is measured to be ~ 450 fs while that of the DFB is measured to be ~ 3 ps. The reduced jitter on

the generated pulses, in the case of the gain switched DM laser, reflects the clearly resolvable sidebands in the corresponding spectrum.

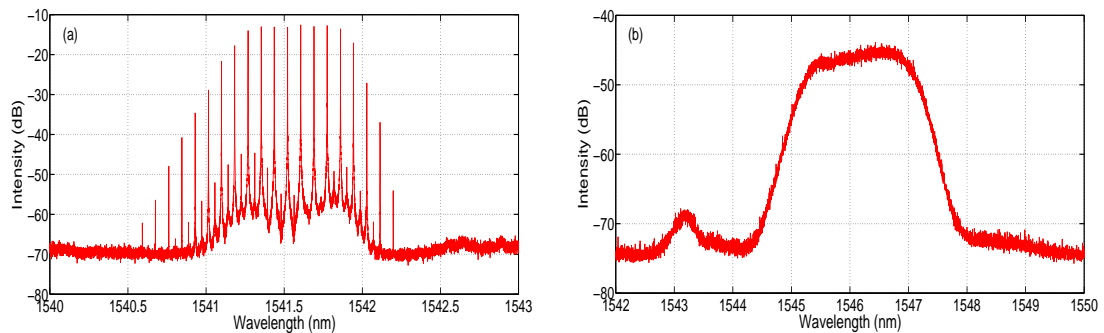

Fig. 6. (a) Optical gain switched spectra for DM laser. (b) Optical gain switched spectra for DFB laser.

The temporal jitter in gain switched laser pulses stems from the fluctuation in the photon density during the buildup of the optical pulse, caused by the random nature of spontaneous emission [19]. Hence, the reduced level of jitter on the gain switched DM laser pulses can be mainly attributed to the lower coupling of the ASE noise into the lasing mode. This principle is further substantiated by the minimization of the spontaneous emission contribution to the temporal jitter of the gain-switched DFB pulses by external injection [20], [21], experimentally verified in section four.

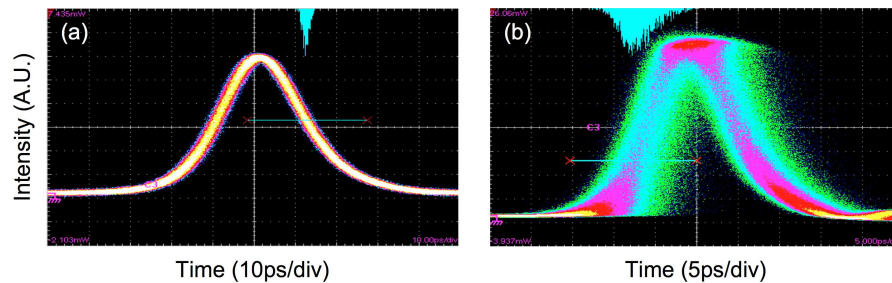

Fig. 7. Temporal jitter on gain switched pulses (a) DM. (b) DFB.

Further characterization of the gain switched DM pulses is carried out using a stepped heterodyne measurement technique that is capable of recovering the amplitude and phase of a periodic optical signal [22]. Fig.8(a) shows the intensity and the chirp profile of the gain switched DM laser pulses obtained by using this technique. The pulse duration is 24ps and more importantly, the total magnitude of the chirp across the pulse is approximately 60GHz. Fig.8(b) shows the intensity and chirp profile of the gain switched DFB laser. In this case, the stepped heterodyne could not be employed to characterize the amplitude and phase essentially due to the lack of discernible frequency tones. The amplitude and phase characterization, in this case, was performed by employing the Frequency Resolved Optical Gating (FROG) technique [23]. The pulse width is measured to be 13ps and the total magnitude of chirp across the pulse is approximately 200GHz. The relatively small chirp across the gain switched DM laser pulse (relative to the gain switched DFB laser pulse) is testament to the previous studies that reported the linewidth enhancement factor of the DM laser to be approximately 2-3 [16].

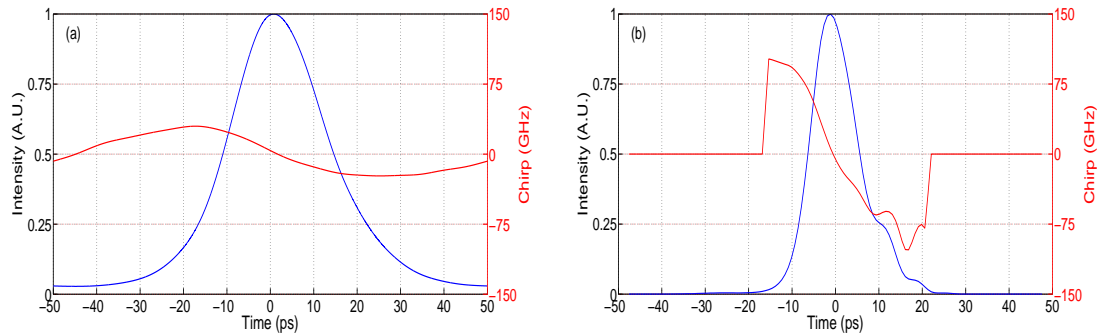

Fig. 8. Temporal intensity and chirp of gain switched (a) DM laser pulse (b) DFB laser pulse.

4. Externally Injected Gain Switched DFB Laser

4.1. Experimental Set-up

Fig.9 depicts the experimental set-up employed to realize the externally injected gain switched transmitter. The transmitter set-up remains unchanged apart from the addition of a second DFB laser for injection. External injection is achieved by employing a master-slave configuration and is realized by using an optical circulator to direct the light from the second DFB laser biased at 23.5mA ($\sim 1.2I_{th}$). A polarization controller (PC) is also used to ensure that the light being injected is aligned to the optical axis of the modulated (slave) laser. The wavelength of the master laser is matched to the slave (with the aid of temperature tuning) and the injected power is approximately 0dBm (measured after port two of the circulator) which ensured low level injection of the slave laser. The generated optical signal is again characterized by using a high resolution (20MHz) optical spectrum analyzer (OSA) and a high-speed oscilloscope ($>65\text{GHz}$) in conjunction with a 50GHz pin detector.

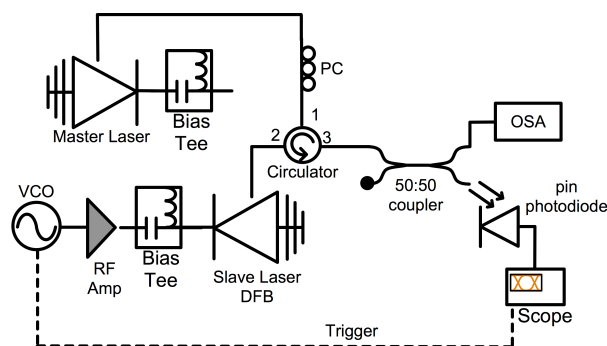

Fig. 9. Experimental set-up for externally injected gain switched DFB laser.

4.2. Results and Discussion

Fig.10(a) and (b) show the optical spectra from the gain switched DFB without and with external optical injection. As can be seen in the free running gain switched DFB, modulation of the laser results in the same significantly broadened spectrum, as previously discussed in section three. However, by injecting light into the gain switched DFB, we notice the generation of sidebands in the lasing mode. The external injection of light provides an excitation of the lasing mode to be well above the level of spontaneous emission thereby reducing the relative fluctuations in the photon density, resulting in a corresponding reduction in timing jitter. The reduction in pulse-to-pulse timing jitter improves the coherence of the pulse train thereby resulting in the presence of spectral

sidebands. Fig.10(b) illustrates that shows that 19 tones are generated within 3dB of the spectral envelope peak. This is approximately 2.5 times greater than the number of sidebands generated by the gain switched DM laser, however the modulation depth is limited to 30dB indicating that the phase co-relation of the emitted pulses and the pulse to pulse stability is still poorer than the gain switched DM laser case.

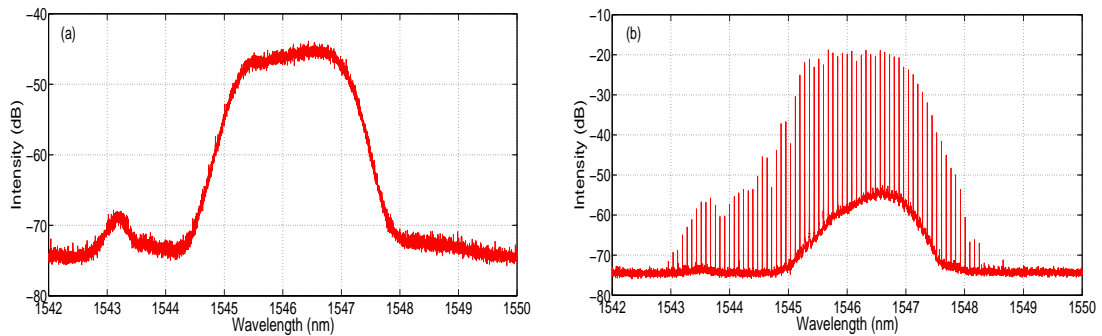

Fig. 10. (a) Optical spectra of gain switched DFB without external injection. (b) With external injection.

Fig.11(a) and (b) show the optical pulses without and with external optical injection. The free running gain switched DFB pulses (Fig.10a) portray the same jitter (~ 3 ps) as mentioned previously in section 3.2. In the case of the externally injected gain switched DFB; the pulse width is measured to be 13ps. More importantly, as shown in Fig.11(b), the rms jitter is reduced to less than 1ps (the Tektronix oscilloscope with the 250fs jitter measurement option used earlier was not available at this time). As mentioned earlier, by injecting photons into the laser cavity the differential gain of the longitudinal mode, whose frequency coincides with the frequency of the injected photons, will be increased thereby suppressing the coupling of spontaneous emission. This prevents the random fluctuations of the photon density thus exhibiting a smaller timing jitter in the output pulses.

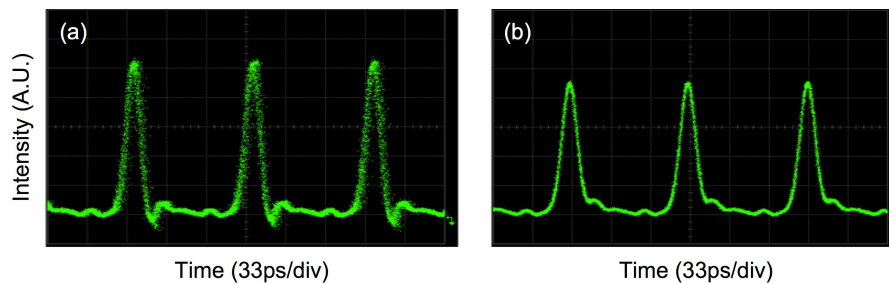

Fig. 11. (a) Pulses of gain switched DFB without external injection. (b) With external injection.

Further characterization of the externally injected gain switched DFB laser pulses in terms of the intensity and chirp profiles, were carried out using the stepped-heterodyne measurement technique and is depicted in Fig.12. It can be clearly seen that the total magnitude of chirp has been reduced from the 200GHz to approximately 140GHz by employing external light injection. This reduction in chirp is due to the inherent suppression in carrier density fluctuations due to external injection and the effects of this suppression is also clearly visible from the coherent comb depicted in Fig.10(b).

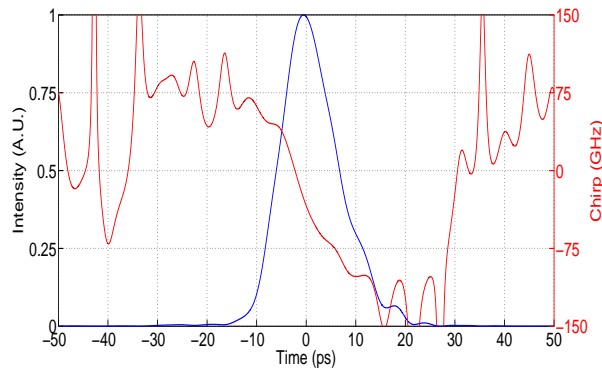

Fig. 12. Temporal intensity and chirp of externally injected gain switched DFB laser.

5. Pulse Compression/Comb Expansion through Self Phase Modulation

The special property of a gain switched DM laser yielding low jitter pulses and a corresponding frequency comb alludes to the fact that it can be employed as a cost efficient transmitter (by filtering individual sidebands) in networks utilizing advanced modulation formats and also in CoWDM transmission systems [24], [25]. The viability of such a source would be vastly improved if the number of generated sidebands could be increased. This may be achieved by exploiting the nonlinear effects in standard single mode fiber. If the peak power of the generated pulses is sufficient, self phase modulation (SPM) effects in the fiber may be induced and when combined with anomalous dispersion, pulse compression occurs. A consequence of pulse compression is a broader spectral envelope. Therefore this technique is employed to multiply the number of frequency tones present in the gain-switched comb spectrum.

5.1. Experimental Set-up

Fig.13 shows the experimental set-up used to compress the generated pulses (red line) and to generate an expanded a low-ripple frequency comb (blue line) from the gain switched DM laser. The transmitter set-up is unchanged and the optical pulses are passed directly into a dispersion compensating fiber (DCF). As shown in Fig.8, the gain switched DM pulses exhibit a predominantly linear chirp with a negative slope across the central part of the pulse, therefore normal dispersion can be employed for compression. The first compression technique (red section in Fig.13) employed a 600m span of DCF with a dispersion of -99ps/nm/km at 1540nm . The pulses are further compressed by the nonlinear technique of higher-order soliton compression in a dispersion shifted fiber (DSF) [26]. A 4.8km span of dispersion shifted fiber is used for the soliton compression and it exhibited a dispersion parameter of 4.5ps/nm/km at 1540nm . For the second scenario (blue section in Fig.13) the linearly compressed pulses are amplified and passed through a second 200m length of DCF followed by a second EDFA and a 950m length of highly-nonlinear fiber (HNLF, dispersion -0.5ps/nm/km) to produce an optical frequency comb optimized for low spectral-ripple. For both compression stages the output signal is split using a passive 3dB optical coupler before being analyzed with a high resolution OSA and a commercially available optical sampling oscilloscope with a sampling bandwidth of 500GHz .

5.2. Results and Discussion

After propagating through the 600m of DCF, the pulse duration of the gain-switched DM laser is reduced from 24ps to 11ps. This compressed pulse has a time-bandwidth product of 0.5, close to the optimum value of 0.44 for a Gaussian pulse. For the higher-order soliton compression this pulse is then amplified to 46 mW average power (peak power 0.42W, soliton number $N \sim 4$) and propagated through 4.8km of DSF. The temporal profile and spectrum of the pulse at the output

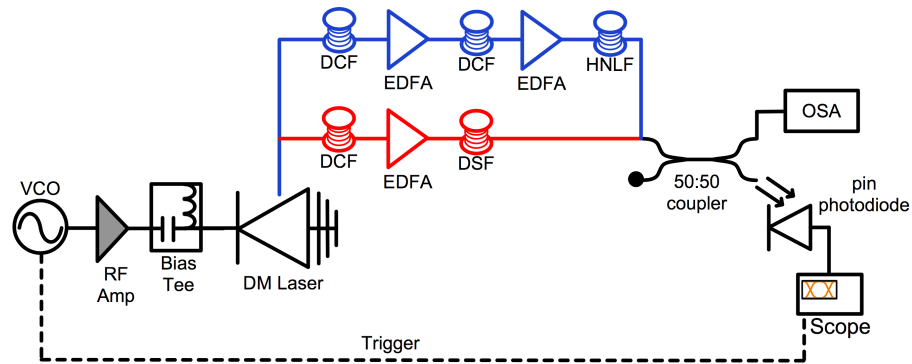

Fig. 13. Experimental setup used to perform linear and non-linear compression of the gain switched pulses and expansion of the frequency comb.

of the DSF is shown in Fig.14. The pulse width after this compression is 2.3ps, and the temporal profile of the pulse is clean apart for the small pedestals either side of the main pulse which are characteristic of higher-order soliton compression [26]. As can be seen in Fig.14(b) the number of frequency tones in the spectrum of the compressed pulse is considerably increased compared to the input pulse. For many applications it is desirable that this expanded frequency comb also possesses a relatively flat spectral profile rather than the peaked spectrum seen in Fig.14(b).

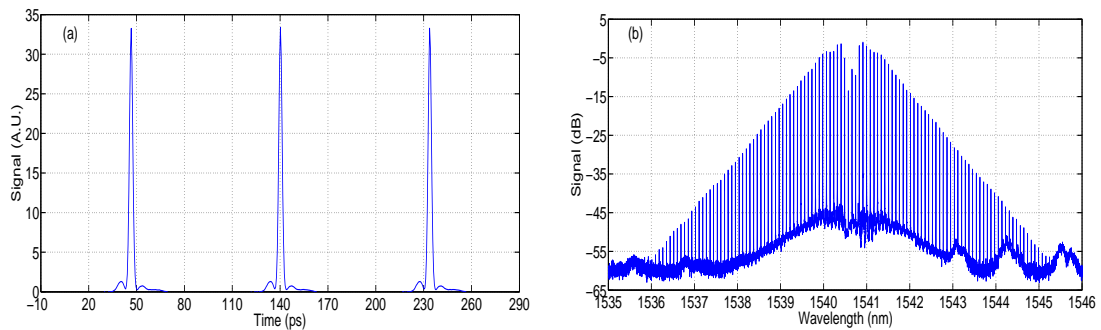

Fig. 14. (a) Compressed gain switched pulse. (b) Corresponding expanded frequency comb spectrum.

This can be achieved using the second configuration shown in Fig.13 (blue line). The fiber lengths and the pump powers used in this setup have been optimized for low spectral ripple using a full simulation of the generalized nonlinear Schrodinger equation including the effects of third order dispersion and the complex Raman susceptibility [26]. After the linear compression stage the pulse is amplified to 100mW average power and passed through a second 200m length of DCF in order to pre-chirp the pulse. The pulse is then amplified to 83mW average power and passed through 950m of highly-nonlinear fiber. The spectrum at the output of the HNLF is shown in Fig.15(a) (blue trace) and exhibits excellent flatness and enhanced spectral width. The frequency spacing and 3dB spectral width of the expanded comb were 10.7GHz and >500GHz, respectively. The number of spectral tones within a 3dB spectral ripple is approximately 50. Also plotted is the result of the nonlinear Schrodinger equation simulation (red trace) used to optimize the comb expansion. The two curves show an excellent agreement. Importantly the frequency tones are still clearly resolvable with a large modulation depth indicating that the phase co-relation and pulse-to-pulse stability remains high, demonstrating improved performance over the externally injected DFB laser. The optimum expansion of the frequency comb is significant as it would allow such a source to act as a multi-wavelength transmitter for implementation in DWDM applications.

Additionally, the low linewidth portrayed by each of the individual sidebands [9] implies that such a transmitter could be used in optical networks that employ spectrally efficient advanced modulation formats, such as m-PSK on each tone. Also, as previously alluded to, the high coherence between the spectral frequency tones enables the use of this transmitter in CoWDM systems [25].

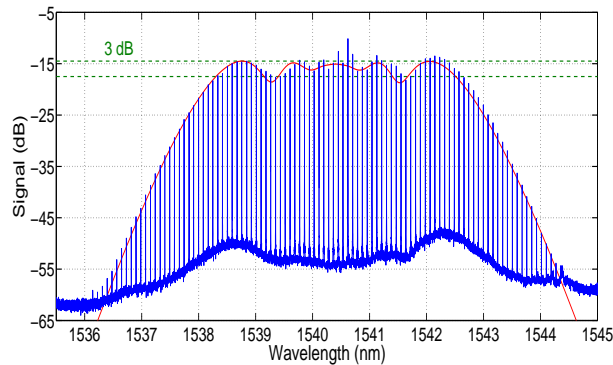

Fig. 15. Expanded comb spectrum of the gain switched DM laser: Measured spectrum (blue trace), numerical simulation (red trace).

6. Conclusions

We have demonstrated an optimized, cost efficient technique of gain switching a discrete mode laser transmitter to generate a coherent optical multi-carrier signal. The gain switched DM laser spectrum portrays efficient sideband generation in the lasing mode with eight 10.7GHz sidebands generated within 3dB of the spectral envelope peak and an extinction ratio in excess of 45dB that signifies excellent coherence properties. The corresponding optical pulses exhibit pulse widths of about 24ps and also display extremely small temporal jitter of ~ 450 fs without the additional complexity of external injection seeding. By incorporating, additional linear and non-linear compression schemes, we have also shown that this transmitter can be considered a potential candidate for high speed multi-carrier transmission systems targeting Tb/s applications and beyond.

Acknowledgements

This work is supported in part by the Enterprise Ireland Commercialization Technology Development Phase (EI CFTD/2008/324) and by the Higher Education Authority Program for Research in Third Level Institutions (2007-2011) via the INSPIRE program.

References

- [1] B. J. C. Schmidt, A. James Lowery, and J. Armstrong, "Experimental demonstrations of 20 Gbit/s direct-detection optical OFDM and 12 Gbit/s with a colorless transmitter," *in proc of Optical Fiber Communications Conference and Exposition and The National Fiber Optic Engineers Conference (OFC/NFOEC)*, 2007, presentation number: PDP18.
- [2] A. Sano, Y. Takatori, and Y. Miyamoto, "No-guard-interval coherent optical OFDM for 100-Gb/s/ch long-haul transmission systems," *in proc of Optical Fiber Communications Conference and Exposition and The National Fiber Optic Engineers Conference (OFC/NFOEC)*, 2009, presentation number: OTuO3.
- [3] W. Shieh, H. Bao, and Y. Tang, "Coherent optical OFDM: theory and design," *OSA Journal Optics Express*, vol. 16, pp. 841-859, 2008.
- [4] A. D. Ellis, and F. C. Garcia-Gunning, "Spectral density enhancement using coherent WDM," *IEEE Photonics Technology Letters*, vol. 17, pp. 504-506, 2005.
- [5] S. L. Jansen, A. A. Amin, H. Takahashi, I. Morita, and H. Tanaka, "132.2-Gb/s PDM-8QAM-OFDM transmission at 4-b/s/Hz spectral efficiency," *IEEE Photonics Technology Letters*, vol. 21, pp. 802-804, 2009.
- [6] C-B. Huang, S-G. Park, D.E. Leaird, and A.M. Weiner, "Nonlinearly broadened phase-modulated continuous-wave laser frequency combs characterized using DPSK decoding," *OSA Journal Optics Express*, vol. 16, pp. 2520-2527, 2008.

- [7] F. Quinlan, S. Gee, S. Ozharar, and P. Delfyett, "Ultralow-jitter and amplitude-noise semiconductor-based actively mode-locked laser," *OSA Optics Letters*, vol. 31, pp. 2870–2872, 2006.
- [8] R. G. M. P. Koumans, and R. Van Roijen, "Theory for passive mode-locking in semiconductor laser structures including the effects of self-phase modulation, dispersion, and pulse collisions," *IEEE Journal of Quantum Electronics*, vol. 32, pp. 478–492, 1996.
- [9] P. M. Anandarajah, K. Shi, J. O'Carroll, A. Kaszubowska, R. Phelan, L. P. Barry, A. D. Ellis, P. Perry, D. Reid, B. Kelly, and J. O'Gorman, "Phase shift keyed systems based on a gain switched laser transmitter," *OSA Journal Optics Express*, vol. 17, pp. 12668–12677, 2009.
- [10] C. Herbert, D. Jones, A. Kaszubowska-Anandarajah, B. Kelly, M. Rensing, J. O'Carroll, R. Phelan, P. Anandarajah, P. Perry, L. P. Barry, and J. O'Gorman, "Discrete mode lasers for communication applications," *IET Optoelectronics*, vol. 3, pp. 1–17, 2009.
- [11] R. Phelan, B. Kelly, J. O'Carroll, C. Herbert, A. Duke, and J. O'Gorman, "–40C < T < 95C mode-hop free operation of an uncooled AlGaInAs-MQW discrete-mode laser diode with emission at 1.3 μ m," *IET Electronics Letters*, vol. 45, pp. 43–45, 2009.
- [12] B. W. Hakki, and T. L. Paoli, "CW degradation at 300 K of GaAs double heterostructure junction lasers. II. Electronic gain," *Journal of Applied Physics*, vol. 44, pp. 4113–4119, 1973.
- [13] Y. Takushima, H. Sotobayashi, M. E. Grein, E. P. Ippen, and H. H. Haus, "Linewidth of mode combs of passively and actively mode locked semiconductor laser diodes," *in Proc. SPIE*, 2004, vol. 5595, pp. 213–227.
- [14] C. H. Henry, "Theory of the linewidth of semiconductor lasers," *IEEE Journal of Selected Topics in Quantum Electronics*, vol. QE-18, pp. 259–264, 1982.
- [15] T. Okoshi, K. Kikuchi, and A. Nakajama, "Novel method for high resolution measurement of laser output measurements," *IET Electronics Letters*, vol. 16, pp. 630–631, 1980.
- [16] R. Fehse, S. O'Brien, S. Osborn, E. P. O'Reilly, J. Patchell, D. Jones, and J. O'Gorman, "Design and implementation of single-mode Fabry-Perot lasers using non-periodic index patterns," *Part of Proceedings of SPIE 6115 Physics and Simulation of Optoelectronic Devices XIV*, 2006, 6115–06.
- [17] P. Anandarajah, L. P. Barry, and A. Kaszubowska, "Performance Issues Associated with WDM Optical Systems using Self-Seeded Gain-Switched Pulse Sources due to Mode Partition Noise Effects," *IEEE Photonics Technology Letters*, vol. 14, pp. 1202–1204, 2002.
- [18] C. Schubert, S. Ferber, M. Kroh, C. Schmidt-Langhorst, R. Ludwig, B. Huttli, R. Kaiser, and H. G. Weber, "40 GHz semiconductor mode locked laser pulse source for 160Gbit/s RZ-DPSK data transmission," *in proc. of European Conference on Optical Communications (ECOC)*, 2005, presentation number: Tu1.5.3.
- [19] M. Jinno, "Correlated and uncorrelated timing jitter in gain switched laser diodes," *IEEE Photonics Technology Letters*, vol. 5, pp. 1140–1143, 1993.
- [20] D. S. Seo, D. Y. Kim, and H. F. Liu, "Timing jitter reduction of gain-switched DFB laser by external injection-seeding," *IET Electronics Letters*, vol. 32, pp. 44–45, 1996.
- [21] A. M. Clarke, P. Anandarajah, and L. P. Barry, "Generation of widely tunable picosecond pulses with large SMSR by externally injecting a gain-switched dual laser source," *IEEE Photonics Technology Letters*, vol. 16, pp. 2344–2346, 2004.
- [22] D. A. Reid, S. G. Murdoch, and L. P. Barry, "Stepped-heterodyne optical complex spectrum analyser," *OSA Journal Optics Express*, vol. 18, pp. 19724–19731, 2010.
- [23] R. Trebino, K. W. DeLong, D. N. Fittinghoff, J. N. Sweetser, M. A. Krumbugel, and B. A. Richman, "Measuring ultrashort laser pulses in the time-frequency domain using frequency-resolved optical gating," *Review of Scientific Instruments*, vol. 68, pp. 3277–3295, 1997.
- [24] A. D. Ellis, F. C. Garcia-Gunning, and T. Healy, "Coherent WDM: The achievement of high information spectral density through phase control within the transmitter," *in proc of Optical Fiber Communications Conference and Exposition and The National Fiber Optic Engineers Conference (OFC/NFOEC)*, 2005, presentation number: OThR4.
- [25] R. Maher, P. M. Anandarajah, S. K. Ibrahim, L. Barry, A. Ellis, P. Perry, R. Phelan, B. Kelly, and J. O'Gorman, "Low cost comb source in a coherent wavelength division multiplexed system," *in proc. of European Conference on Optical Communications (ECOC)*, 2010, presentation number: We. P3.07.
- [26] G. P. Agrawal, "Applications of nonlinear fiber optics," *Academic Press*, 2001.